

Your Inspection Report



45 Pinehurst Cres
Toronto, ON M9A 3A4



PREPARED FOR:
ANA SANTOS

INSPECTION DATE:
Friday, September 4, 2020

PREPARED BY:
Philip Falcone, RHI



Carson, Dunlop & Associates Ltd.
120 Carlton Street, Suite 407
Toronto, ON M5A 4K2

416-964-9415
www.carsondunlop.com
inspection@carsondunlop.com

Excellence in home inspection



September 3, 2020

Dear Ana Santos,

RE: Report No. 73379
45 Pinehurst Cres
Toronto, ON
M9A 3A4

Thank you for choosing us to perform your home inspection. We hope the experience met your expectations.

The enclosed report includes an Overview tab which summarizes key findings, and the report body. The Good Advice tab provides helpful tips for looking after your home; the Reference tab includes a 500-page Reference Library; and the Appendix tab includes valuable added benefits. You can navigate by clicking the tabs at the top of each page.

To the prospective buyer: We strongly recommend an Onsite Review of the home to help you understand the inspection report and protect your investment. The Review includes a tour of the home with the inspector, a complimentary safety recall service on appliances and ensures that you can take advantage of the special offers listed in the appendix most of them are free. You also receive free technical support for as long as you own your home. The Onsite Review fee is \$260.

Thanks again for choosing Carson Dunlop.

Sincerely,

Philip Falcone, RHI
on behalf of
Carson, Dunlop & Associates Ltd.

Carson, Dunlop & Associates Ltd.
120 Carlton Street, Suite 407
Toronto, ON M5A 4K2
416-964-9415
www.carsondunlop.com
inspection@carsondunlop.com

OVERVIEW

45 Pinehurst Cres, Toronto, ON September 4, 2020

Report No. 73379

www.carsondunlop.com

OVERVIEW

ROOFING

EXTERIOR

STRUCTURE

ELECTRICAL

HEATING

COOLING

INSULATION

PLUMBING

INTERIOR

OUR ADVICE

APPENDIX

REFERENCE

This Overview lists some of the significant report items if any were identified. Please read the entire report before making any decisions about the home; do not rely solely on the Overview.

FOR THE BUYER

There are two elements to a home inspection - the inspection itself and the report. This report is helpful, but the inspection is equally important. You need both elements to make an informed decision. Call us at 416-964-9415 to book an Onsite Review with the inspector, or engage your own inspector. Our fee is \$260. Without an Onsite Review, our obligation and liability are limited to the seller.

When you move into the home you may find some issues not identified in the report. That is to be expected for a number of reasons, such as furniture and storage that has been removed, changes to the property conditions, etc. Therefore, we suggest you allow roughly 1% of the value of the home annually for maintenance and repair.

Here are a few thoughts to help you stay warm, safe and dry in your home.

All homes require regular maintenance and periodic updates. Maintenance programs help keep homes safe, comfortable and efficient. Roofs, furnaces and air conditioners for example, wear out and have to be replaced. Good maintenance extends the life of these house systems. Refer to Our Advice tab for more details regarding maintenance of your home.

Water is the biggest enemy of homes, whether from leaks through the roof, walls or foundation, or from plumbing inside the home. Preventative maintenance and quick response to water problems are important to minimize damage, costs and help prevent mould.

Environmental consultants can help with issues like mould, indoor air quality and asbestos. If you need help in these areas, we can connect you with professionals.

All recommendations in the report should be addressed by qualified specialists. Our ballpark costs and time frames are provided as a courtesy and should be confirmed with quotes from specialists. Minor costs in the report are typically under \$1,000.

END OF OVERVIEW

Description

Sloped roofing material:

- [Asphalt shingles](#)



Asphalt shingles

- Flat roofing material: • [Modified bitumen membrane](#)

Observations and Recommendations

RECOMMENDATIONS \ General

Condition: • The roof inspection was restricted by limited access. A full evaluation is recommended to provide more information about the condition of the roof. This may be incorporated in an annual roof maintenance plan.

SLOPED ROOF FLASHINGS \ General notes

Condition: • Inspect during annual tune-up.

*Carefully inspect flashings at roof/wall intersections, chimney's, plumbing stacks and flat roof areas for example.

Inspection Methods and Limitations

Roof inspection limited/prevented by: • Roof was wet • Lack of access (too high/steep)

Inspection performed: • From roof edge

Description

General: • The exterior has been well maintained and is in good condition. • Several components have been updated.

Wall surfaces and trim: • [Brick](#) • Wood siding

Observations and Recommendations

ROOF DRAINAGE \ Downspouts

Condition: • Downspouts that discharge below grade may leak or be clogged, resulting in water in the basement or crawlspace.

Discharge points not identified.

While the current arrangement is convenient and a good method to deal with rain water, if the drain pipe becomes clogged and/or deteriorated, there is a greater risk of water backing up and leaking into the basement. Note: On newer houses the drain may go into the weeping tile (not the floor drain).

Task: Re-direct downspouts to discharge above grade at least 6 feet from home.

Time: If necessary

Condition: • [Discharge onto roofs](#)

*Upper roof discharges onto lower roof - In order to help prevent pre-mature wear of lower roof surface, a downspout extension into the lower gutter system is recommended.

Location: Rear

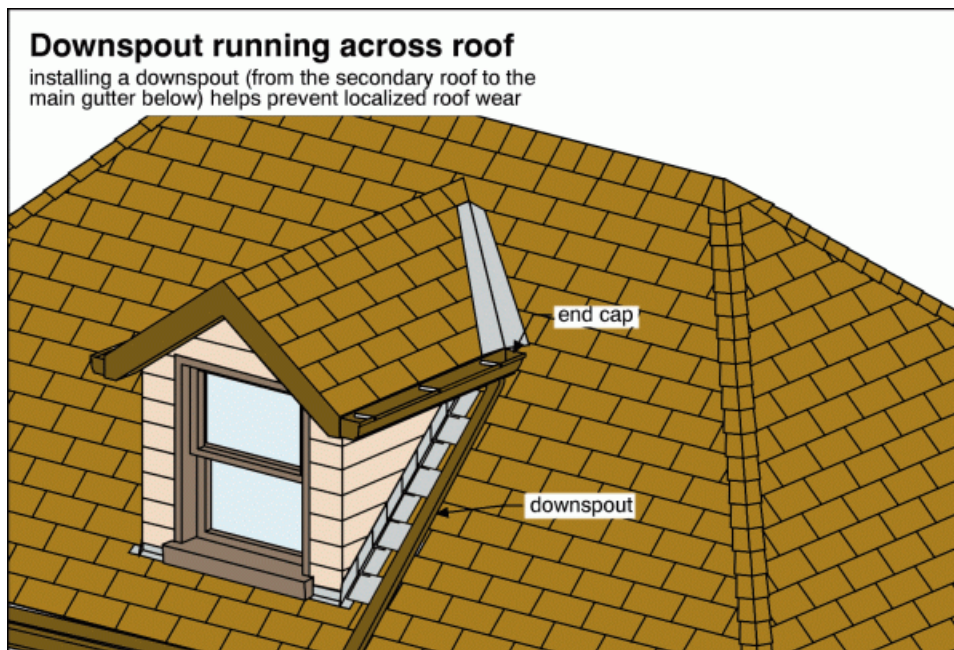

DOORS \ General notes

Condition: • Threshold too low

*Keep area clear of snow and debris to help prevent water infiltration. Ensure sealant at threshold and around door frame is kept in good repair.

Location: Rear Patio

LANDSCAPING \ General notes

Condition: • Raised gardens against the house

Because gardens tend to see water more frequently, these could be areas where moisture could enter the basement area. If basement leakage becomes an issue, relocation of the garden(s) may be necessary.

Task: Monitor and re-arrange if necessary.

Time: Ongoing

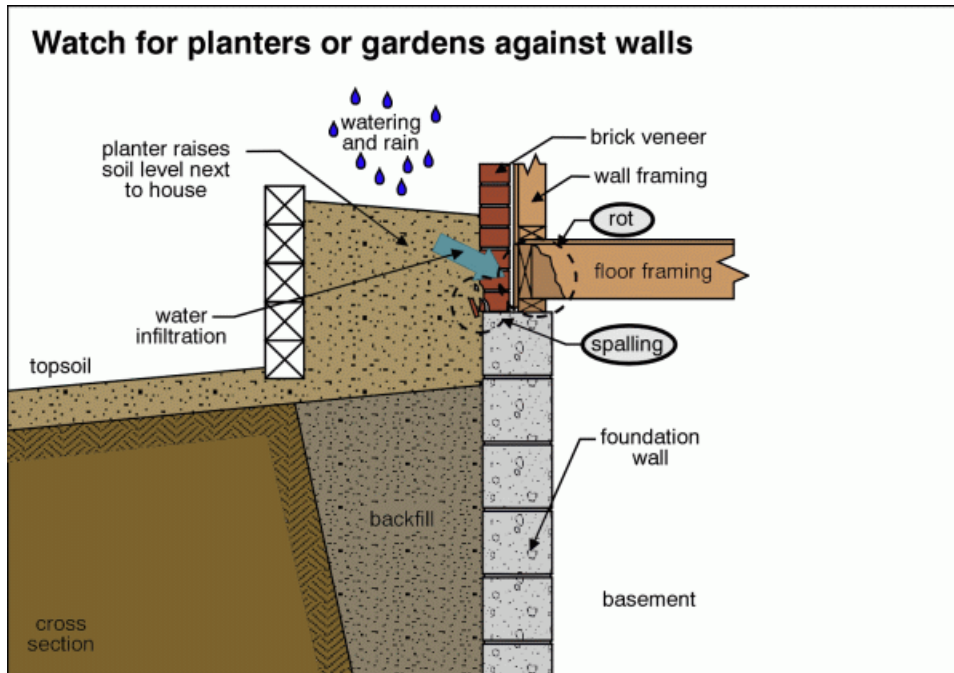

LANDSCAPING \ Lot grading

Condition: • The ground around some parts of the home does not slope to drain water away from the foundation.

*Low areas at various sections around the house. A neutral or negative slope will hold moisture against the foundation and increase the possibility of water infiltration. Poor grading tends to pool water, creating a slip hazard in cold weather. Maintain a positive slope away from the house to help flush water away from the building. Low areas tend to pool water and keep it against the building making water infiltration more likely.

Task: Improve grading so the ground slopes down at least 1 inch per foot for the first 6 feet away from the home. Note: Less slope is needed on hard surfaces like driveways

Time: If necessary

LANDSCAPING \ Retaining wall

Condition: • [Bowling or bulging](#)

Slight bowing of wall noted. Railing missing.

Location: Rear

Task: Monitor / Improve

Time: When necessary

EXTERIOR

45 Pinehurst Cres, Toronto, ON September 4, 2020

Report No. 73379

www.carsondunlop.com

OVERVIEW

ROOFING

EXTERIOR

STRUCTURE

ELECTRICAL

HEATING

COOLING

INSULATION

PLUMBING

INTERIOR

OUR ADVICE

APPENDIX

REFERENCE

GARAGE \ Vehicle doors

Condition: • Weatherstripping damaged or missing.

*Better seal required at base of vehicle door.

Task: Repair

Inspection Methods and Limitations

Inspection limited/prevented by: • New finishes/paint/trim • Storage

Inspection limited/prevented by: • Garage not entered.

Exterior inspected from: • Ground level

STRUCTURE

45 Pinehurst Cres, Toronto, ON September 4, 2020

Report No. 73379

www.carsondunlop.com

OVERVIEW

ROOFING

EXTERIOR

STRUCTURE

ELECTRICAL

HEATING

COOLING

INSULATION

PLUMBING

INTERIOR

OUR ADVICE

APPENDIX

REFERENCE

Description

General: • The structure has performed well, with no evidence of significant movement.

Configuration: • [Basement](#)

Foundation material: • [Masonry block](#) • Not visible in areas

Floor construction: • [Joists](#)

Exterior wall construction: • [Wood frame](#) • [Masonry](#)

Roof and ceiling framing: • [Rafters/roof joists](#)

Observations and Recommendations

FOUNDATIONS \ General notes

Condition: • Cracks are potential sources of Basement (or Crawl space) dampness or leakage. See INTERIOR: BASEMENT LEAKAGE.

FLOORS \ Concrete slabs

Condition: • Concrete basement, crawlspace and garage floors are not typically part of the structure. Almost all basement, crawlspace and garage concrete floors have minor shrinkage and settlement cracks.

Description

General: • The electrical system has been substantially updated.

Service size: • [200 Amps \(240 Volts\)](#)

Main disconnect/service box type and location:

- [Breakers - basement](#)

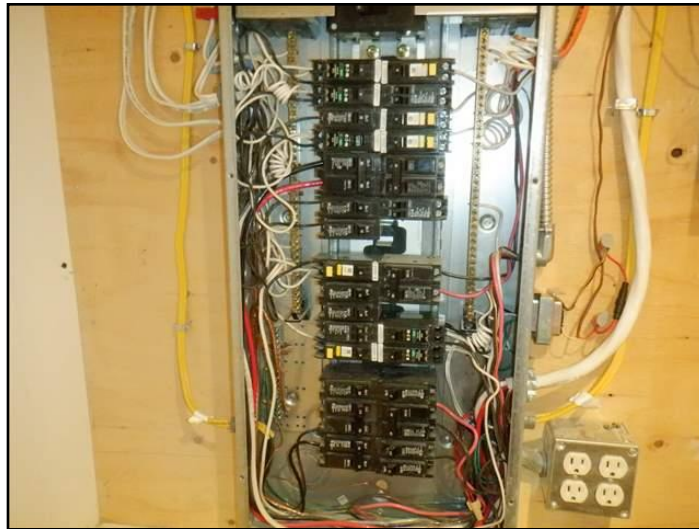

Breakers - basement

Distribution panel type and location:

- [Breakers - utility room](#)

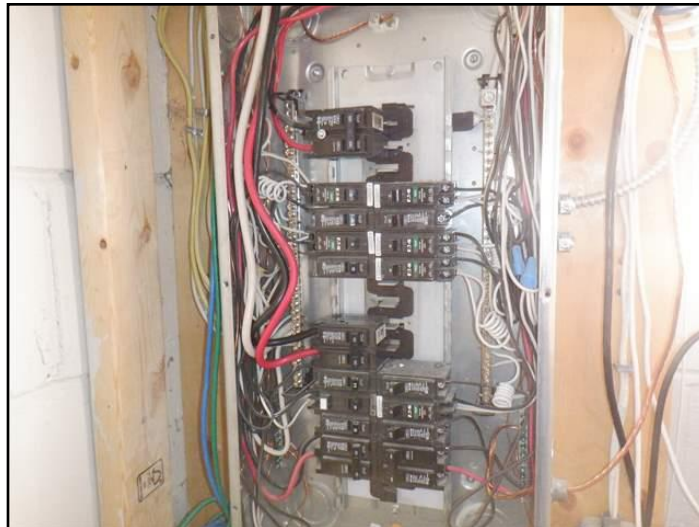

Breakers - utility room

Distribution wire (conductor) material and type: • [Copper - non-metallic sheathed](#) • [Copper - metallic sheathed](#)

Circuit interrupters: Ground Fault (GFCI) & Arc Fault (AFCI): • GFCIs present • [AFCIs present](#)

OVERVIEW	ROOFING	EXTERIOR	STRUCTURE	ELECTRICAL	HEATING	COOLING	INSULATION	PLUMBING	INTERIOR
OUR ADVICE	APPENDIX	REFERENCE							

Observations and Recommendations

RECOMMENDATIONS \ General

Condition: • All electrical recommendations are safety issues. Treat them as high priority items, and consider the Time frame as Immediate, unless otherwise noted.

SERVICE BOX, GROUNDING AND PANEL \ Distribution panel

Condition: • [Double taps](#)

Location: Labeled as 'Panel Plugs'

Task: Correct

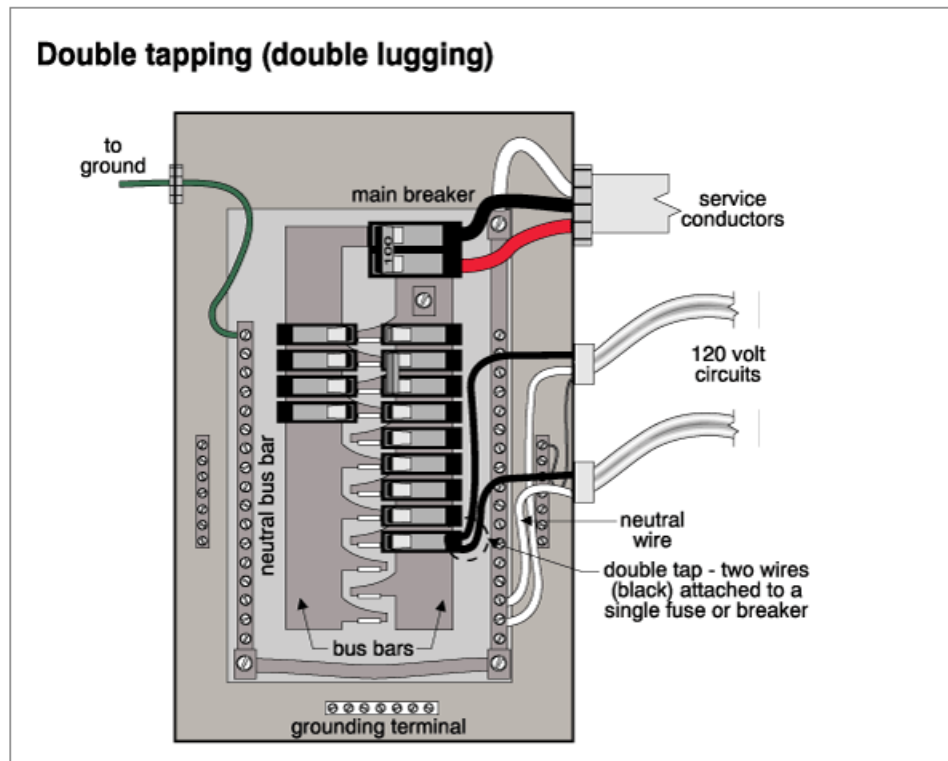

DISTRIBUTION SYSTEM \ Outlets (receptacles)

Condition: • [Inoperative](#)

*There may be a primary switch turned off or tripped - not found.

Location: Front Right (looking from street) Exterior Wall

Condition: • [Loose](#)

*Cover missing - Provide.

Location: Furnace Room

Task: Secure

OVERVIEW

ROOFING

EXTERIOR

STRUCTURE

ELECTRICAL

HEATING

COOLING

INSULATION

PLUMBING

INTERIOR

OUR ADVICE

APPENDIX

REFERENCE

Inspection Methods and Limitations

Inspection limited/prevented by: • Main disconnect cover not removed - unsafe to do so.

Description

General: • The high-efficiency furnace should have several years of life remaining.

System type: • [Furnace](#)

Fuel/energy source: • [Gas](#)

Approximate capacity: • [80,000 BTU/hr](#)

Efficiency: • [High-efficiency](#)

Approximate age: • [4 years](#)

Typical life expectancy:

• Furnace (high efficiency) 15 to 20 years



Furnace (high efficiency) 15 to 20 years

Fireplace/stove: • [Wood-burning fireplace](#) • Electric fireplace

Observations and Recommendations

FURNACE \ General notes

Condition: • Unknown abandoned pipe noted.

Location: Furnace Area

Task: Further evaluation

HEATING

45 Pinehurst Cres, Toronto, ON September 4, 2020

Report No. 73379

www.carsondunlop.com

OVERVIEW

ROOFING

EXTERIOR

STRUCTURE

ELECTRICAL

HEATING

COOLING

INSULATION

PLUMBING

INTERIOR

OUR ADVICE

APPENDIX

REFERENCE



Unknown abandoned pipe



Unknown abandoned pipe

FURNACE \ Filter

Condition: • Dirty filter

Task: Replace

Time: Regular maintenance

FIREPLACE \ General notes

Condition: • Before you use the fireplace, it should be inspected, cleaned and improved if necessary by a WETT (Wood Energy Technology Transfer Inc.) certified technician

Hearth extension dimensions

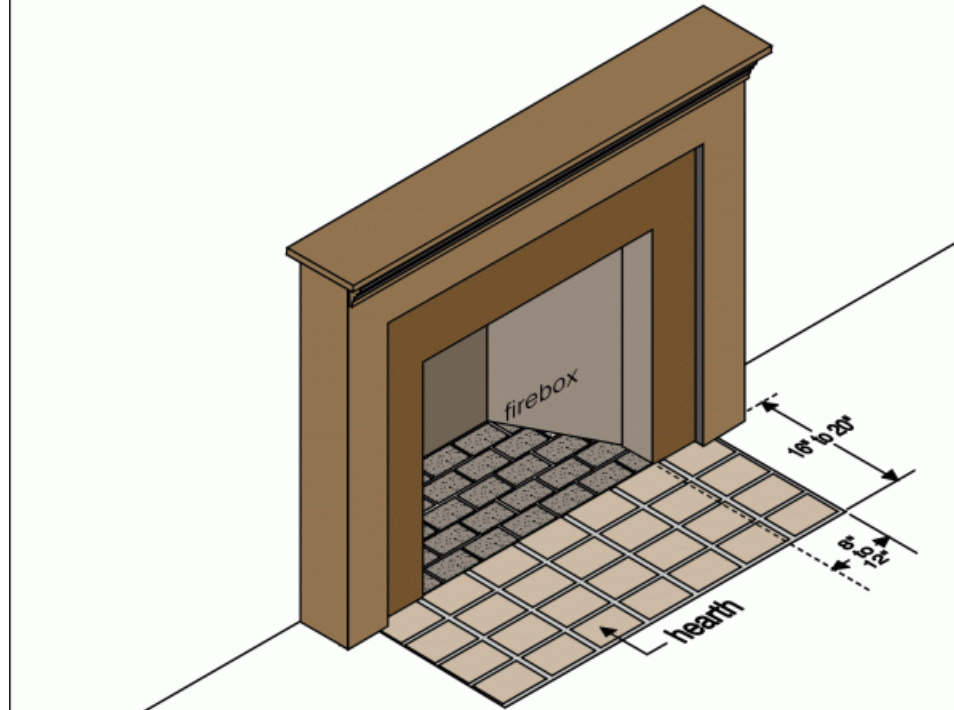

Inspection Methods and Limitations

Inspection prevented/limited by: • Basement fireplace not tested (inoperative remote)

Warm weather: • Prevents testing heating effectiveness

Environmental issues are outside the scope of a home inspection: • This includes issues such as asbestos.

Description

Air conditioning type:

- [Air cooled](#)



Air cooled

Cooling capacity: • [24,000 BTU/hr](#)

Compressor approximate age: • 7 years

Typical life expectancy: • 10 to 15 years

Observations and Recommendations

AIR CONDITIONING \ Life expectancy

Condition: • The home is equipped with a 7-year old air conditioner. These systems are complex with life expectancies of 10 to 15 years, if well maintained and serviced regularly. An annual maintenance contract is strongly recommended to improve comfort, reduce energy costs and prolong the life of the equipment. See Appendix for more information.

Description

Attic/roof insulation material:

- Fiberglass



Fiberglass

Attic/roof insulation amount/value: • [R-32](#)

Attic/roof air/vapor barrier: • Not determined

Observations and Recommendations

ATTIC/ROOF \ Insulation

Condition: • [Gaps or voids](#)

*Uneven. For best results, insulation should be fluffy and uniform throughout attic space.

Task: Improve

ATTIC/ROOF \ Roof vents

Condition: • Vent screen dirty/obstructed.

Location: Left Side Attic

Task: Clean

Time: Regular maintenance

CRAWLSPACE \ Hatch/Door

Condition: • Not insulated and not weatherstripped

Task: Improve

Time: Less than 1 year

Cost: Minor

INSULATION AND VENTILATION

45 Pinehurst Cres, Toronto, ON September 4, 2020

Report No. 73379

www.carsondunlop.com

OVERVIEW

ROOFING

EXTERIOR

STRUCTURE

ELECTRICAL

HEATING

COOLING

INSULATION

PLUMBING

INTERIOR

OUR ADVICE

APPENDIX

REFERENCE

Inspection Methods and Limitations

Inspection limited/prevented by lack of access to: • Wall space - access not gained.

Attic inspection performed: • By entering attic, but access was limited

Roof ventilation system performance: • Not evaluated

Description

General: • The kitchen and bathrooms have been updated.

Service piping into building: • [Copper](#)

Supply piping in building: • [Copper](#) • PEX (cross-linked Polyethylene)

Main water shut off valve at the:

- Front of the basement



Main water shut-off valve

Water heater type: • [Conventional](#)

Water heater fuel/energy source: • Electricity

Water heater approximate age: • 5 years

Waste and vent piping in building: • [Plastic](#) • Not visible in some areas.

Floor drain location: • Furnace area

Backwater valve:

- None noted

*These valves help prevent sewer backup. Many insurance companies insist these be installed before they will offer a sewer backup endorsement.

**Ask Seller if one has been installed and if so, verify its location.

Observations and Recommendations

RECOMMENDATIONS \ General

Condition: • Many plumbing fixtures may be expected to last 15 years or more, although faucets are often replaced every 10 years.

WASTE PLUMBING \ Drain piping - performance

Condition: • This Specialty Service is free to all Carson Dunlop clients by simply calling 416-626-1785. A video

inspection of the waste plumbing is recommended to determine whether there are tree roots, other obstructions, or damaged pipe. This is common on older properties, especially when mature trees are nearby. This is a great precautionary measure and can help prevent a sewage backup, although many homeowners wait until there are problems with the drains.

FIXTURES AND FAUCETS \ Basin, sink and laundry tub

Condition: • Drain stop ineffective

Location: Basement Bathroom Basin

Task: Repair

Time: If desired

FIXTURES AND FAUCETS \ Shower stall enclosure

Condition: • Shower door handle loose.

Location: Basement Bathroom

Task: Repair

Inspection Methods and Limitations

Items excluded from a building inspection: • Tub/sink overflows

Description

General: • Interior finishes are in good repair overall. • The newer windows help improve comfort and energy efficiency.

Observations and Recommendations

WINDOWS \ Storms and screens

Condition: • [Missing](#)

*Possibly in storage? Ask Seller for details.

BASEMENT \ Leakage

Condition: • Almost every basement (and crawlspace) leaks under the right conditions. Based on a one-time visit, it's impossible to know how often or severe leaks may be. While we look for evidence of past leakage during our consultation, this is often not a good indicator of current conditions. Exterior conditions such as poorly performing gutters and downspouts, and ground sloping down toward the house often cause basement leakage problems. Please read Section 10.0 in the Interior section of the Home Reference Book before taking any action. You can find this in the Reference tab at the end of the report.

To summarize, wet basement issues can be addressed in 4 steps:

1. First, ensure gutters and downspouts carry roof run-off away from the home. (relatively low cost)
2. If problems persist, slope the ground (including walks, patios and driveways) to direct water away from the home. (Low cost if done by homeowner. Higher cost if done by contractor or if driveways, patios and expensive landscaping are disturbed.)
3. If the problem is not resolved and the foundation is poured concrete, seal any leaking cracks and form-tie holes from the inside. (A typical cost is \$300 to \$600 per crack or hole.)
4. As a last resort, dampproof the exterior of the foundation, provide a drainage membrane and add/repair perimeter drainage tile. (High cost)

Condition: • Basement leakage frequency or severity cannot be predicted during a home inspection

COMMENTS \ Additional

Condition: • Slightly elevated moisture levels noted in this area of the basement. Follow the steps in this section to systematically improve the exterior as best possible to divert as much moisture as possible away from the house. Cost will increase as you proceed down the list. Generally speaking, controlling your downspouts and providing improved grading will offer the most benefit for the least cost. See other comments in Exterior and Interior sections for best strategies to minimize the potential for future water problems in the basement. A dehumidifier is also advised (especially for the summer).

Location: Base of Staircase

OVERVIEW	ROOFING	EXTERIOR	STRUCTURE	ELECTRICAL	HEATING	COOLING	INSULATION	PLUMBING	INTERIOR
OUR ADVICE	APPENDIX	REFERENCE							

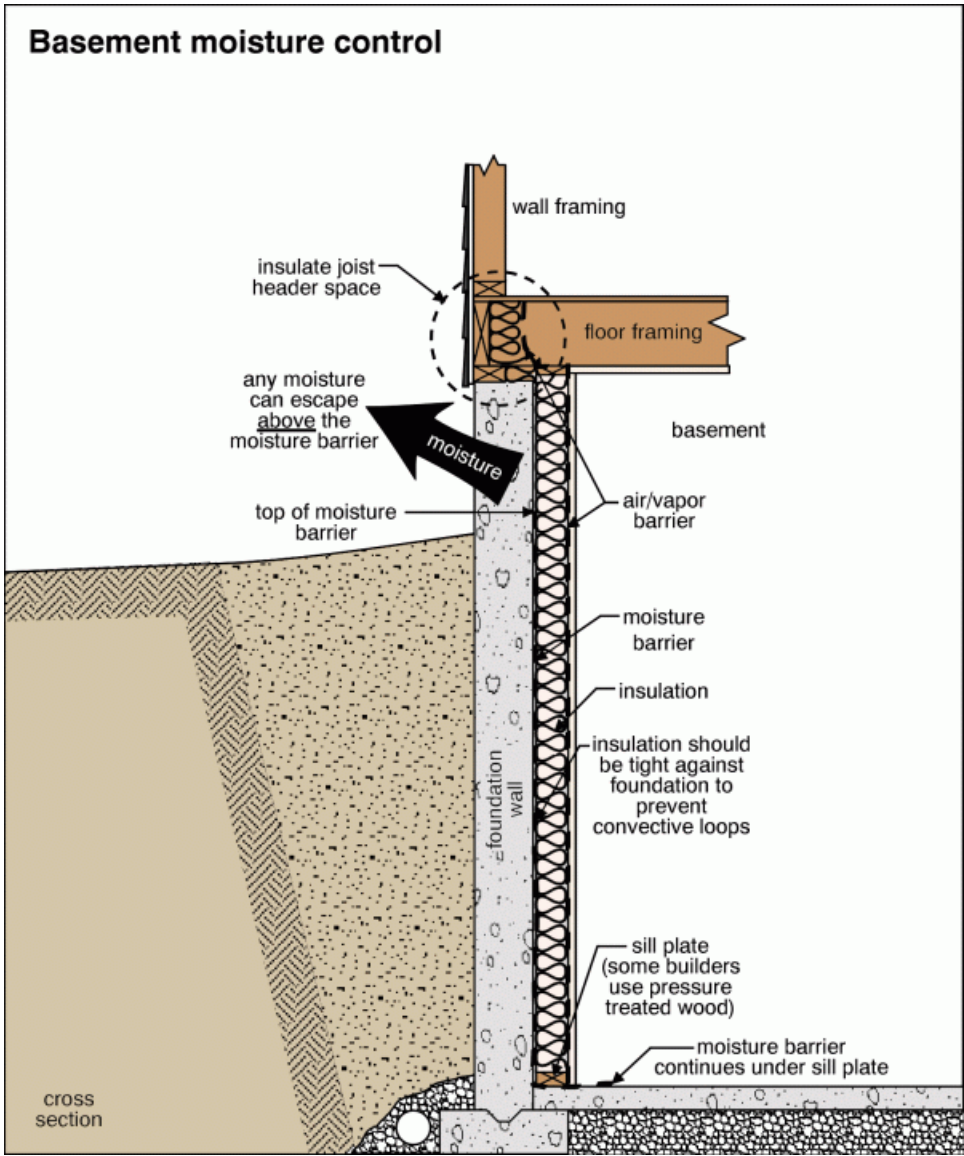

Inspection Methods and Limitations

Inspection limited/prevented by: • New finishes/paint

Inspection limited/prevented by: • Raised or finished floors in basements can trap moisture and lead to problems associated with mold growth. While we don't advocate removal of these types of floors as a matter of course, understand that it is impossible to know the state of the underside of the floor. Conditions may be discovered if renovations are undertaken that were not visible during the inspection.

Percent of foundation not visible: • 80 %

Description

OUR ADVICE FOR LOOKING AFTER YOUR HOME: • Home maintenance is an important responsibility. It protects your investment, extends life expectancy and helps avoid significant expenses. This document is an integral part of the report, and will help you avoid many common problems and reduce costs.

Priority Maintenance and Home Set-Up: • The Home Set-Up and Maintenance chapter in the Home Reference Book provides important information regarding things that are done once when moving in, as well as regular maintenance activities.

Please be sure to follow these maintenance guidelines. The Home Reference Book is included under the REFERENCE tab in this report.

Basement/Crawlspace Leakage: • Basement water leakage is the most common problem with homes. Almost every basement and crawlspace leaks under the right conditions. Good maintenance of exterior grading, gutters and downspouts is critically important.

For more details, please refer to Section 10 of the Interior chapter of the Home Reference Book, which is in the REFERENCE tab in this report.

Roof - Annual Maintenance: • It is important to set up an annual inspection and tune-up program to minimize the risk of leakage and maximize the life of the roof. Roof leaks may occur at any time and are most often at penetrations or changes in material. A leak does not necessarily mean the roof needs to be replaced.

Roof coverings are disposable and have to be replaced from time to time. Asphalt shingles, for example, last roughly 15 years. • Roof coverings are disposable and have to be replaced from time to time. Asphalt shingles, for example, last roughly 15 years.

Exterior - Annual Maintenance: • Annual inspection of the exterior is important to ensure weather-tightness and durability of exterior components. Grading around the home should slope to drain water away from the foundation to help keep the basement dry.

Painting and caulking should be well maintained. Particular attention should be paid to horizontal surfaces where water may collect.

Joints, intersections, penetrations and other places where water may enter the building assembly should be checked and maintained regularly.

Garage Door Operators: • The auto reverse mechanism on your garage door opener should be tested monthly. The door should also reverse when it meets reasonable resistance, or if the 'photo eye' beam is broken.

Electrical System - Label the Panel: • Each circuit in the electrical panel should be labelled to indicate what it controls. This improves both safety and convenience. Where the panel is already labelled, the labelling should be verified as correct. Do not rely on existing labeling.

Ground Fault Circuit Interrupters and Arc Fault Circuit Interrupters: • These should be tested monthly using the test buttons on the receptacles or on the breakers in the electrical panel.

Heating and Cooling System - Annual Maintenance: • Set up an annual maintenance agreement that covers parts and labour for all heating and cooling equipment. This includes gas fireplaces and heaters, as well as furnaces, boilers and air conditioners. Include humidifiers and electronic air cleaners in the service agreement. Arrange the first visit as soon

as possible after taking possession.

Check filters for furnaces and air conditioners monthly and change or clean as needed. Duct systems have to be balanced to maximize comfort and efficiency, and to minimize operating costs. Adjust the balancing for heating and cooling seasons, respectively.

For hot water systems, balancing should be done by a specialist to due to the risk of leakage at radiator valves. These valves are not operated during a home inspection. • Check filters for furnaces and air conditioners monthly and change or clean as needed. Duct systems have to be balanced to maximize comfort and efficiency, and to minimize operating costs. Adjust the balancing for heating and cooling seasons, respectively. • For hot water systems, balancing should be done by a specialist to due to the risk of leakage at radiator valves. These valves are not operated during a home inspection.

Bathtub and Shower Maintenance: • Caulking and grout in bathtubs and showers should be checked every 6 months, and improved as necessary to prevent leakage and water damage behind walls and below floors.

Water Heaters: • All water heaters should be flushed by a specialist every year to maximize performance and life expectancy. This is even more critical on tankless water heaters.

Washing Machine Hoses: • We suggest braided steel hoses rather than rubber hoses for connecting washing machines to supply piping in the home. A ruptured hose can result in serious water damage in a short time, especially if the laundry area is in or above a finished part of the home.

Clothes Dryer Vents: • We recommend that vents for clothes dryers discharge outside the home. The vent material should be smooth walled (not corrugated) metal, and the run should be as short and straight as practical. This reduces energy consumption and cost, as well as drying time for clothes. It also minimizes the risk of a lint fire inside the vent.

Lint filters in the dryer should be cleaned every time the dryer is used. There is a secondary lint trap in many condominiums. These should be cleaned regularly. There may also a duct fan controlled by a wall switch. The fan should be ON whenever the dryer is used.

Dryer ducts should be inspected annually and cleaned as necessary to help reduce the risk of a fire, improve energy efficiency and reduce drying times.

Fireplace and Wood Stove Maintenance: • Wood burning appliances and chimneys should be inspected and cleaned before you use them, and annually thereafter. We recommend that specialists with a WETT (Wood Energy Technology Transfer, Inc.) designation perform this work. Many insurance companies require a WETT inspection for a property with a wood burning device.

Smoke and Carbon Monoxide (CO) Detectors/Alarms: • Smoke detectors are required at every floor level of every home, including basements and crawlspaces. Even if these are present when you move into the home, we recommend replacing the detectors. We strongly recommend photoelectric smoke detectors rather than ionization type detectors. Carbon monoxide detectors should be provided adjacent to all sleeping areas.

These devices are not tested during a home inspection. Detectors should be tested every 6 months, and replaced every 10 years. Batteries for smoke and carbon monoxide detectors should be replaced annually. If unsure of the age of a smoke detector, it should be replaced.

Backwater Valve: • A backwater valve protects your home from a backup of the municipal sewer system. The valve may be equipped with an alarm to notify you of a backup. Please note: if the valve is closed due to a municipal sewer backup, you cannot use the plumbing fixtures in the home. The waste water is unable to leave the building and will back up through floor drains and the lowest plumbing fixtures. • The valve should be inspected and cleaned as necessary at least twice a year. The video provides instructions on how to do this. - <https://www.youtube.com/watch?v=vJN9YKvnIYk>

Sump Pump: • A sump pump collects storm water below the basement floor and discharges it safely to the exterior to prevent flooding. The discharge point should be at least 6 feet (2 m) away from the home. Best installations include backup power for the sump pump, so it will work in the event of a power outage. A high water alarm in the sump pump will notify you if the pump fails. Some installations include a backup pump.

The sump and pump should be inspected and tested four times a year.

For condominium owners: • Condominium owners - Maintenance and Repairs: There are two types of repairs that may be performed in a condo - repairs to an individual condo unit and repairs to common elements. Common elements are set out in the Condominium Declaration and will differ from one building to another. If repairs must be made inside your unit, you are responsible for making the repairs at your own expense. You are also responsible for the ongoing maintenance of your unit. The condominium corporation's board of directors is responsible for maintenance and repair of the common elements. Exclusive-use common elements, such as parking spaces or balconies are generally maintained by the condominium board.

Be Ready for Emergencies: Be sure you know where to shut off the water. Some condos have more than one shut off, and others need a special tool (key) to turn off water. Label each circuit on the electrical panel, and make sure you should know how to turn off the power. Keep a fire extinguisher suitable for grease fires near the kitchen.

Property Manager and Concierge/Security: Keep the contact information for these folks handy (perhaps on your phone) wherever you are. • Lint filters in the dryer should be cleaned every time the dryer is used. There is a secondary lint trap in many condominiums. These should be cleaned regularly. There may also a duct fan controlled by a wall switch. The fan should be ON whenever the dryer is used.

END OF REPORT



As a Carson Dunlop client, you receive complimentary membership in the Carson Dunlop Homeowners Association. Don't forget to take advantage of all the savings you receive just for being a member.



Free Heating or Cooling Tune-Up from AtlasCare (\$200 value)

To redeem, please call **416-626-1785** and ask for the Carson Dunlop promo.



Free Sewer Videoscan (\$350 value)

To redeem, please call **416-626-1785** and ask for the Carson Dunlop promo.



A free 1-year Jiffy+ exclusive membership (\$200 value) program where homeowners access member rates, perks and benefits on all your household repair and maintenance items all year round (*up to \$500 savings*).

Click [here](#) to get started.

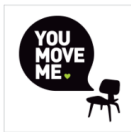

\$100 Gift Card from You Move Me (Moving Company)

<https://www.youmoveme.com/ca/save-100-off-moving-services>



\$70 Gift Card from 1-800-GOT-JUNK?

<https://www.1800gotjunk.com/ca/en/carson-dunlop>



David Slack Insurance Brokers LTD.

Save 15% off home and auto insurance with David Slack Insurance Brokers.

Call **800-971-1363** and speak to Dave Slack.

Questions? Call us at 800-268-7070

This is a copy of our home inspection contract and outlines the terms, limitations and conditions of the home inspection

THIS CONTRACT LIMITS THE LIABILITY OF THE HOME INSPECTION COMPANY.

PLEASE READ CAREFULLY BEFORE SIGNING.

The term Home Inspector in this document means the Home Inspector and the Home Inspection Company. The inspection is performed in substantial accordance with the **STANDARDS OF PRACTICE** of the Ontario Association of Home Inspectors. We comply with the Standards, inspecting every listed item, although we do not include descriptions of all items. To review the STANDARDS OF PRACTICE, click <http://www.oahi.com/download.php?id=138>. There is also a copy attached herewith.

The Home Inspector's report is an opinion of the present condition of the property, based on a visual examination of the readily accessible features of the building.

In addition to the limitations in the STANDARDS, the Inspection of this property is subject to Limitations and Conditions set out in this Agreement.

LIMITATIONS AND CONDITIONS OF THE HOME INSPECTION

The focus of the inspection is on major issues that may affect a reasonable person's decision to buy a home.

A Home Inspector is a generalist, rather than a specialist. The home inspection is a non-invasive performance review, rather than a design review. Home Inspectors do not perform calculations to determine whether mechanical, electrical and structural systems for example, are properly sized.

1) THE INSPECTION IS NOT TECHNICALLY EXHAUSTIVE.

The Inspection is a sampling exercise and is not technically exhaustive. The focus is on major issues, and while looking for major issues, we typically come across some smaller issues. These are included in the report as a courtesy, but it should be understood that not all issues will be identified.

Establishing the significance of an issue may be beyond the scope of the inspection. Further evaluation by a specialist may be required.

A Technical Audit is a more in-depth, technically exhaustive inspection of the home that provides more information than a Home Inspection. We have both services available. By accepting this agreement, you acknowledge that you have chosen a Home Inspection instead of a Technical Audit.

If you are concerned about any conditions noted in the Home Inspection Report, we strongly recommend that you consult a qualified specialist to provide a more detailed analysis.

2) THE INSPECTION IS AN OPINION OF THE PRESENT CONDITION OF THE VISIBLE COMPONENTS.

A Home Inspection does not include identifying defects that are hidden behind walls, floors or ceilings, storage or furniture. This includes inaccessible elements such as wiring, heating, cooling, structure, plumbing and insulation.

Intermittent problems may not be visible on a Home Inspection because they only happen under certain circumstances. For example, your Home Inspector may not discover leaks that occur only during certain weather conditions or when a specific tap or appliance is being used in everyday life.

Home Inspectors will not find conditions that are concealed by finishes, storage or furnishings. Inspectors do not remove wall coverings (including wallpaper), lift flooring (including carpet) or move storage or furniture.

Representative sampling is used for components where there are several similar items. The list includes but is not limited to – roof shingles, siding, masonry, windows, interior doors, electrical wiring, receptacles and switches, plumbing pipes, heating ducts and pipes, attic insulation and air/vapor barriers, and floor, wall and ceiling surfaces.

3) THIS IS NOT A CODE-COMPLIANCE INSPECTION

Home Inspectors do NOT determine whether or not any aspect of the property complies with past or present codes (such as building codes, electrical codes, fuel codes, fire codes, etc.), regulations, laws, by-laws, ordinances or other regulatory requirements. Codes change regularly, and most homes will not comply with current codes.

4) THE INSPECTION DOES NOT INCLUDE HAZARDOUS MATERIALS.

This includes building materials that are now suspected of posing a risk to health such as phenol-formaldehyde and urea-formaldehyde based insulation, fiberglass insulation and vermiculite insulation. Inspectors do NOT identify asbestos in roofing, siding, wall, ceiling or floor finishes, insulation or fireproofing. Inspectors do NOT look for lead or other toxic metals in such things as pipes, paint or window coverings. Health scientists can help in these areas.

The Inspection does not deal with environmental hazards such as the past use of insecticides, fungicides, herbicides or pesticides. Home Inspectors do NOT look for, or comment on, the past use of chemical termite treatments in or around the property.

5) WE DO NOT COMMENT ON THE QUALITY OF AIR IN A BUILDING.

The Inspector does not determine if there are irritants, pollutants, contaminants, or toxic materials in or around the building.

The Inspection does not include spores, fungus, mould or mildew. You should note that whenever there is water damage noted in the report, there is a possibility that mould or mildew may be present, unseen behind a wall, floor or ceiling.

If anyone in your home suffers from allergies or heightened sensitivity to quality of air, we strongly recommend that you consult a qualified Environmental Consultant who can test for toxic materials, mould and allergens at additional cost.

OVERVIEW

ROOFING

EXTERIOR

STRUCTURE

ELECTRICAL

HEATING

COOLING

INSULATION

PLUMBING

INTERIOR

OUR ADVICE

APPENDIX

REFERENCE

6) WE DON'T LOOK FOR BURIED TANKS.

Home Inspectors do not look for fuel oil, septic or gasoline tanks that may be buried on the property. If there are fuel oil or other storage tanks on the property, you may be responsible for their removal and the safe disposal of any contaminated soil. If you suspect there is a buried tank, we strongly recommend that you retain a qualified Environmental Consultant to investigate.

7) CANCELLATION FEE

If the inspection is cancelled within 24 hours of the appointment time, a cancellation fee of 50% of the fee will apply.

8) THERMAL IMAGING (If included with this inspection)

The use of a thermal imager by your home inspector is for the purpose of screening for water leakage issues. While the use of this equipment improves the odds of detecting a moisture issue, it is not a guarantee, as numerous environmental conditions can mask the thermal signature of moisture. Additionally, leakage is often intermittent, and cannot be detected when not present.

9) MOULD ASSESSMENT (If included with this inspection)

The services provided include a complete visual inspection from basement to attic for signs of water intrusion and mould growth. Moisture readings will be collected throughout the home. Two indoor air samples and one outdoor reference sample will be collected. Should visible mould growth be identified, one surface sample will be collected. The results of the sample and investigation will be summarized in our written report.

10) REPORT IS FOR OUR CLIENT ONLY.

The inspection report is for the exclusive use of the client named herein. The client may provide the report to prospective buyers, at their own discretion. Potential buyers are required to obtain their own Onsite Review with Carson Dunlop if they intend to rely on this report. Carson Dunlop will not be responsible for the use of or reliance upon this Report by any third party without an Onsite Review.

11) NOT A GUARANTEE, WARRANTY OR INSURANCE POLICY.

The inspection and report are not a guarantee, warranty or an insurance policy with regard to the fitness of the property.

12) TIME TO INVESTIGATE

We will have no liability for any claim or complaint if conditions have been disturbed, altered, repaired, replaced or otherwise changed before we have had a reasonable period of time to investigate.

13) LIMIT OF LIABILITY

THE LIABILITY OF THE HOME INSPECTOR AND THE HOME INSPECTION COMPANY ARISING OUT OF THIS INSPECTION AND REPORT, FOR ANY CAUSE OF ACTION WHATSOEVER, WHETHER IN CONTRACT OR IN NEGLIGENCE, IS LIMITED TO A REFUND OF THE FEES THAT YOU HAVE BEEN CHARGED FOR THIS INSPECTION OR \$1,000, WHICHEVER IS GREATER.

The client agrees that any claim, for negligence, breach of contract or otherwise, be made in writing and reported to Carson Dunlop within 10 business days of discovery. Further, the client agrees to allow Carson Dunlop the opportunity to re-inspect the claimed discrepancy except for an emergency condition, before the client or client's agent, employees or

independent contractor repairs, replaces, alters or modifies the claimed discrepancy. The client understands and agrees that any failure to notify Carson Dunlop as stated above shall constitute a waiver of any and all claims the client may have against the inspector and/or Carson Dunlop.

14) TIME PERIOD

The Client acknowledges and agrees that the timeframe for commencement of legal proceedings by the Client against the Inspector for damages suffered by the Client as a result of alleged errors, omissions, breaches of contract and/or negligence by the Inspector shall not be later than two (2) years from the date of the inspection.

15) LEGAL ADVICE

The Client has had such legal advice as the Client desires in relation to the effect of this Contract on the Client's legal rights.

16) CLIENT'S AGREEMENT

The Client understands and agrees to be bound by each and every provision of this contract. The Client has the authority to bind any other family members or other interested parties to this Contract.



Canadian Association Of Home & Property Inspectors

2012 NATIONAL STANDARDS OF PRACTICE

The National Standards of Practice are a set of guidelines for home and property inspectors to follow in the performance of their inspections. They are the most widely accepted Canadian home inspection guidelines in use, and address all the home's major systems and components. The National Standards of Practice and Code of Ethics are recognized by many related professionals as the definitive Standards for professional performance in the industry.

These National Standards of Practice are being published to inform the public on the nature and scope of visual building inspections performed by home and property inspectors who are members of the Canadian Association of Home and Property Inspectors (CAHPI).

The purpose of the National Standards of Practice is to provide guidelines for home and property inspectors regarding both the inspection itself and the drafting of the inspection report, and to define certain terms relating to the performance of home inspections to ensure consistent interpretation.

To ensure better public protection, home and property inspectors who are members of CAHPI should strive to meet these Standards and abide by the appropriate provincial/regional CAHPI Code of Ethics.

These Standards take into account that a visual inspection of a building does not constitute an evaluation or a verification of compliance with building codes, Standards or regulations governing the construction industry or the health and safety industry, or Standards and regulations governing insurability.

Any terms not defined in these Standards shall have the meaning commonly assigned to it by the various trades and professions, according to context.

INDEX

1. Introduction
2. Purpose and Scope
3. General Limitations and Exclusions
4. Structural Systems
5. Exterior Systems
6. Roof Systems
7. Plumbing Systems
8. Electrical Systems
9. Heating Systems
10. Fireplaces & Solid Fuel Burning Appliances
11. Air Conditioning Systems
12. Interior Systems
13. Insulation and Vapour Barriers
14. Mechanical and Natural Ventilation Systems

Glossary Note: Italicized words are defined in the Glossary.

1. INTRODUCTION

1.1 The Canadian Association of Home and Property Inspectors (CAHPI) is a not-for-profit association whose members include the following seven provincial/regional organizations: CAHPI-British Columbia, CAHPI-Alberta, CAHPI-Saskatchewan, CAHPI-Manitoba, OAH (Ontario), AIBQ (Quebec), and CAHPI-Atlantic. CAHPI strives to promote excellence within the profession and continual improvement of inspection services to the public.

2. PURPOSE AND SCOPE

2.1 The purpose of these National Standards of Practice is to establish professional and uniform Standards for private, fee-paid home inspectors who are members of one of the provincial/regional organizations of CAHPI. Home Inspections performed to these National Standards of Practice are intended to provide information regarding the condition of the systems and components of the building as inspected at the time of the Home Inspection. This does NOT include building code inspections.

These National Standards of Practice enable the building being inspected to be compared with a building that was constructed in accordance with the generally accepted practices at the time of construction, and which has been adequately maintained such that there is no significant loss of *functionality*.

It follows that the building may not be in compliance with current building codes, standards and regulations that are applicable at the time of inspection.

These National Standards of Practice apply to inspections of part or all of a building for the following building types:

- single-family dwelling, detached, semi-detached or row house
- multi unit residential building
- residential building held in divided or undivided co ownership
- residential building occupied in part for a residential occupancy and in part for a commercial occupancy, as long as the latter use does not exceed 40% of the building's total area, excluding the basement.

2.2 THE INSPECTOR SHALL:**A. inspect:**

1. *readily accessible*, visually observable *installed systems*, and *components* of buildings listed in these National Standards of Practice.

B. report:

1. on those *systems* and *components* installed on the building inspected which, in the professional opinion or judgement of the *inspector*, *have a significant deficiency* or are unsafe or are near the end of their *service lives*.
2. a reason why, if not self-evident, the *system* or *component* has a *significant deficiency* or is unsafe or is near the end of its *service life*.
3. the inspector's recommendations to correct or monitor the reported deficiency.
4. on any *systems* and *components* designated for inspection in these National Standards of Practice which were present at the time of the *Home Inspection* but were not inspected and a reason they were not inspected.

2.3 *These National Standards of Practice are not intended to limit inspectors from:*

- A.** including other inspection services in addition to those required by these National Standards of Practice provided the *inspector* is appropriately qualified and willing to do so.
- B.** excluding *systems* and *components* from the inspection if requested by the client or as dictated by circumstances at the time of the inspection.

3. GENERAL LIMITATIONS AND EXCLUSIONS**3.1 GENERAL LIMITATIONS:**

- A.** Inspections performed in accordance with these National Standards of Practice
 1. are not *technically exhaustive*.
 2. will not identify concealed conditions or latent defects.

3.2 GENERAL EXCLUSIONS:

A. The *inspector* is not required to perform any action or make any determination unless specifically stated in these National Standards of Practice, except as may be required by lawful authority.

B. *Inspectors* are NOT required to determine:

1. condition of *systems* or *components* which are not readily accessible.
2. remaining life of any *system* or *component*.
3. strength, adequacy, effectiveness, or efficiency of any *system* or *component*.
4. causes of any condition or deficiency.
5. methods, materials, or costs of corrections.
6. future conditions including, but not limited to, failure of *systems* and *components*.
7. suitability of the property for any use.
8. compliance with regulatory requirements (codes, regulations, laws, ordinances, etc.).
9. market value of the property or its marketability.
10. advisability of the purchase of the property.
11. presence of potentially hazardous plants, animals or insects including, but not limited to wood destroying organisms, diseases or organisms harmful to humans.
12. presence of any environmental hazards including, but not limited to toxins, carcinogens, noise, and contaminants in soil, water, and air.
13. effectiveness of any *system* installed or methods utilized to control or remove suspected hazardous substances.
14. operating costs of *systems* or *components*.
15. acoustical properties of any *system* or *component*
16. design adequacy with regards to location of the home, or the elements to which it is exposed.

C. *Inspectors* are NOT required to offer or perform:

1. any act or service contrary to law, statute or regulation.
2. *engineering, architectural* and technical services.
3. work in any trade or any professional service other than *home inspection*.
4. warranties or guarantees of any kind.

D. *Inspectors* are NOT required to operate:

1. any *system* or *component* which is *shut down* or otherwise inoperable.
2. any *system* or *component* which does not respond to *normal operating controls*.
3. shut-off valves.

E. *Inspectors* are NOT required to enter:

1. any area which will, in the opinion of the *inspector*, likely be hazardous to the *inspector* or other persons or damage the property or its *systems* or *components*.

2. *confined spaces*.

3. spaces which are not readily accessible.

F. *Inspectors* are NOT required to *inspect*:

1. underground items including, but not limited to storage tanks or other indications of their presence, whether abandoned or active.
2. *systems* or *components* which are not *installed*.
3. *decorative* items.
4. *systems* or *components* located in areas that are not readily accessible in accordance with these National Standards of Practice.
5. detached structures.
6. common elements or common areas in multi-unit housing, such as condominium properties or cooperative housing when inspecting an individual unit(s), including the roof and building envelope.
7. test and/or operate any installed fire alarm system, burglar alarm system, automatic sprinkler system or other fire protection equipment, electronic or automated installations, telephone, intercom, cable/internet systems and any lifting equipment, elevator, freight elevator, wheelchair lift, climbing chair, escalator or others;
8. pools, spas and their associated safety devices, including fences.

G. *Inspectors* are NOT required to:

1. perform any procedure or operation which will, in the opinion of the *inspector*, likely be hazardous to the *inspector* or other persons or damage the property or its *systems* or *components*.
2. move suspended ceiling tiles, personal property, furniture, equipment, plants, soil, snow, ice, or debris.
3. *dismantle* any *system* or *component*, except as explicitly required by these National Standards of Practice.

4. STRUCTURAL SYSTEMS

4.1 THE INSPECTOR SHALL:

A. inspect:

1. *structural components* including visible foundation and framing.
2. by *probing* a sample of structural components where deterioration is suspected or where clear indications of possible deterioration exist. *Probing* is NOT required when *probing* would damage any finished surface or where no deterioration is visible.

B. describe:

1. foundation(s).
2. floor structure(s).
3. wall structure(s).
4. ceiling structure(s).
5. roof structure(s).

C. report:

1. on conditions limiting access to structural components.
2. methods used to *inspect* the *under-floor crawl space*
3. methods used to *inspect* the attic(s).

4.2 THE INSPECTOR IS NOT REQUIRED TO:

- A. provide any *engineering service* or *architectural service*.
- B. offer an opinion as to the adequacy of any *structural system* or *component*.

5. EXTERIOR SYSTEMS

5.1 THE INSPECTOR SHALL:

A. inspect:

1. exterior wall covering(s), flashing and trim.
2. all exterior doors.
3. attached or *adjacent* decks, balconies, steps, porches, and their associated railings.
4. eaves, soffits, and fascias where accessible from the ground level.
5. vegetation, grading, and surface drainage on the property when any of these are likely to adversely affect the building.
6. walkways, patios, and driveways leading to dwelling entrances.
7. landscaping structure attached or adjacent to the building when likely to adversely affect the building.
8. attached garage or carport.
9. garage doors and garage door operators for attached garages.

B. describe

1. exterior wall covering(s).

C. report:

1. the method(s) used to inspect the exterior wall elevations.

5.2 THE INSPECTOR IS NOT REQUIRED TO:

A. inspect:

1. screening, shutters, awnings, and similar seasonal accessories.
2. fences.
3. geological, geotechnical or hydrological conditions.
4. *recreational facilities*.
5. detached garages and outbuildings.
6. seawalls, break-walls, dykes and docks.
7. erosion control and earth stabilization measures.

6. ROOF SYSTEMS

6.1 THE INSPECTOR SHALL:

A. inspect:

1. *readily accessible* roof coverings.
2. *readily accessible* roof drainage systems.
3. *readily accessible* flashings.
4. *readily accessible* skylights, chimneys, and roof penetrations.

B. describe

1. roof coverings.

C. report:

1. method(s) used to inspect the roof(s).

6.2 THE INSPECTOR IS NOT REQUIRED TO:

A. inspect:

1. antennae and satellite dishes.
2. interiors of flues or chimneys.
3. other *installed* items attached to but not related to the roof system(s).

7. PLUMBING SYSTEMS

7.1 THE INSPECTOR SHALL:

A. inspect:

1. interior water supply and distribution *systems* including all fixtures and faucets.
2. drain, waste and vent *systems* including all fixtures.
3. water heating equipment and associated venting systems.
4. water heating equipment fuel storage and fuel distribution systems.
5. fuel storage and fuel distribution *systems*.
6. drainage sumps, sump pumps, and related piping.

B. describe:

1. water supply, distribution, drain, waste, and vent piping materials.
2. water heating equipment including the energy source.
3. location of main water and main fuel shut-off valves.

7.2 THE INSPECTOR IS NOT REQUIRED TO:**A. inspect:**

1. clothes washing machine connections.
2. wells, well pumps, or water storage related equipment.
3. water conditioning *systems*.
4. solar water heating *systems*.
5. fire and lawn sprinkler *systems*.
6. private waste disposal *systems*.

B. determine:

1. whether water supply and waste disposal *systems* are public or private.
2. the quantity or quality of the water supply.

C. operate:

1. safety valves or shut-off valves.

8. ELECTRICAL SYSTEMS**8.1 THE INSPECTOR SHALL:****A. inspect:**

1. service drop.
2. service entrance conductors, cables, and raceways.
3. service equipment and main disconnects.
4. service grounding.
5. interior components of service panels and sub panels.
6. distribution conductors.
7. overcurrent protection devices.
8. a *representative number* of *installed* lighting fixtures, switches, and receptacles.
9. ground fault circuit interrupters (GFCI) (if appropriate).
10. arc fault circuit interrupters (AFCI) (if appropriate).

B. describe:

1. amperage and voltage rating of the service.
2. location of main disconnect(s) and subpanel(s).
3. *wiring methods*.

C. report:

1. presence of solid conductor aluminum branch circuit wiring.
2. absence of carbon monoxide detectors (if applicable).
3. absence of smoke detectors.
4. presence of ground fault circuit interrupters (GFCI).
5. presence of arc fault circuit interrupters (AFCI).

8.2 THE INSPECTOR IS NOT REQUIRED TO:**A. inspect:**

1. remote control devices unless the device is the only control device.
2. alarm *systems* and *components*.
3. low voltage wiring, *systems* and *components*.
4. ancillary wiring, *systems* and *components* not a part of the primary electrical power distribution *system*.

5. telecommunication equipment.

B. measure:

1. amperage, voltage, or impedance.

9. HEATING SYSTEMS**9.1 THE INSPECTOR SHALL:****A. inspect:**

1. *readily accessible* components of *installed* heating equipment.
2. vent systems, flues, and chimneys.
3. fuel storage and fuel distribution *systems*.

B. describe:

1. energy source(s).
2. heating method(s) by distinguishing characteristics.
3. chimney(s) and/or venting material(s).
4. combustion air sources.
5. exhaust venting methods (naturally aspirating, induced draft, direct vent, direct vent sealed combustion).

9.2 THE INSPECTOR IS NOT REQUIRED TO:**A. inspect:**

1. interiors of flues or chimneys.
2. heat exchangers.
3. auxiliary equipment.
4. electronic air filters.
5. solar heating *systems*.

B. determine:

1. system adequacy or distribution balance.

10. FIREPLACES AND SOLID FUEL BURNING APPLIANCES

(Unless prohibited by the authority having jurisdiction)

10.1 THE INSPECTOR SHALL:**A. inspect:**

1. system components
2. vent systems and chimneys

B. describe:

1. fireplaces and solid fuel burning appliances
2. chimneys

10.2 THE INSPECTOR IS NOT REQUIRED TO:**A. inspect:**

1. interior of flues or chimneys
2. screens, doors and dampers
3. seals and gaskets
4. automatic fuel feed devices
5. heat distribution assists whether fan assisted or gravity

B. ignite or extinguish fires**C. determine draught characteristics****D. move fireplace inserts, stoves, or firebox contents**

OVERVIEW

ROOFING

EXTERIOR

STRUCTURE

ELECTRICAL

HEATING

COOLING

INSULATION

PLUMBING

INTERIOR

OUR ADVICE

APPENDIX

REFERENCE

11. AIR CONDITIONING SYSTEMS**11.1 THE INSPECTOR SHALL:****A. inspect**

1. permanently *installed* central air conditioning equipment.

B. describe:

1. energy source.
2. cooling method by its distinguishing characteristics.

11.2 THE INSPECTOR IS NOT REQUIRED TO:**A. inspect**

1. electronic air filters.
2. portable air conditioner(s).

B. determine:

1. system adequacy or distribution balance.

12. INTERIOR SYSTEMS**12.1 THE INSPECTOR SHALL:****A. inspect:**

1. walls, ceilings, and floors.
2. steps, stairways, and railings.
3. a *representative number* of countertops and *installed* cabinets.
4. a *representative number* of doors and windows.
5. walls, doors and ceilings separating the habitable spaces and the garage.

B. describe:

1. materials used for walls, ceilings and floors.
2. doors.
3. windows.

C. report

1. absence or ineffectiveness of guards and handrails or other potential physical injury hazards.

12.2 THE INSPECTOR IS NOT REQUIRED TO:**A. inspect:**

1. *decorative* finishes.
2. window treatments.
3. central vacuum *systems*.
4. *household appliances*.
5. *recreational facilities*.

13. INSULATION AND VAPOUR BARRIERS**13.1 THE INSPECTOR SHALL:****A. inspect:**

1. insulation and *vapour barriers* in unfinished spaces.

B. describe:

1. type of insulation material(s) and *vapour barriers* in unfinished spaces.

C. report

1. absence of insulation in unfinished spaces within the building envelope.
2. presence of vermiculite insulation

13.2 THE INSPECTOR IS NOT REQUIRED TO:**A. disturb**

1. insulation.
2. *vapour barriers*.

B. obtain sample(s) for analysis

1. insulation material(s).

14. MECHANICAL AND NATURAL VENTILATION SYSTEMS**14.1 THE INSPECTOR SHALL:****A. inspect:**

1. ventilation of attics and foundation areas.
2. mechanical ventilation *systems*.
3. ventilation systems in areas where moisture is generated such as kitchen, bathrooms, laundry rooms.

B. describe:

1. ventilation of attics and foundation areas.
2. mechanical ventilation *systems*.
3. ventilation systems in areas where moisture is generated such as: kitchens, bathrooms and laundry rooms.

C. report:

1. absence of ventilation in areas where moisture is generated such as: kitchens, bathrooms and laundry rooms.

14.2 THE INSPECTOR IS NOT REQUIRED TO:

1. determine indoor air quality.
2. determine system adequacy or distribution balance.

GLOSSARY

Adjacent

Nearest in space or position; immediately adjoining without intervening space.

Alarm Systems

Warning devices, installed or free-standing, including but not limited to; carbon monoxide detectors, flue gas and other spillage detectors, security equipment, ejector pumps and smoke alarms.

Architectural Service

Any practice involving the art and science of building design for construction of any structure or grouping of structures and the use of space within and surrounding the structures or the design for construction, including but not specifically limited to, schematic design, design development, preparation of construction contract documents, and administration of the construction contract, adequacy of design for the location and exposure to the elements.

Automatic Safety Controls

Devices designed and installed to protect *systems* and *components* from unsafe conditions.

Component

A part of a *system*.

Confined Spaces

An enclosed or partially enclosed area that:

1. Is occupied by people only for the purpose of completing work.
2. Has restricted entry/exit points.
3. Could be hazardous to people entering due to:
 - a. its design, construction, location or atmosphere.
 - b. the materials or substances in it, or
 - c. any other conditions which prevent normal inspection procedure.

Decorative

Ornamental; not required for the operation of the essential *systems* and *components* of a building.

Describe

To *report* a *system* or *component* by its type or other observed, significant characteristics to distinguish it from other *systems* or *components*.

Determine

To find out, or come to a conclusion by investigation.

Dismantle

To take apart or remove any component, device, or piece of equipment that would not be taken apart or removed by a homeowner in the course of normal and routine home owner maintenance.

Engineering Service

Any professional service or creative work requiring engineering education, training, and experience and the application of special knowledge of the mathematical, physical and engineering sciences to such professional service or creative work as consultation, investigation, evaluation, planning, design and supervision of construction for the purpose of assuring compliance with the specifications and design, in conjunction with structures, buildings, machines, equipment, works or processes.

Functionality

The purpose that something is designed or expected to fulfill.

Further Evaluation

Examination and analysis by a qualified professional, tradesman or service technician beyond that provided by the *home inspection*.

Home Inspection

The process by which an *inspector* visually examines the *readily accessible systems* and *components* of a building and which *describes* those *systems* and *components* in accordance with these National Standards of Practice.

Household Appliances

Kitchen, laundry, and similar appliances, whether *installed* or freestanding.

Inspect

To examine *readily accessible systems* and *components* of a building in accordance with these National Standards of Practice, *where applicable* using *normal operating controls* and opening *readily openable access panels*.

Inspector

A person hired to examine any *system* or *component* of a building in accordance with these National Standards of Practice.

Installed

Set up or fixed in position for current use or service.

Monitor

Examine at regular intervals to detect evidence of change.

Normal Operating Controls

Devices such as thermostats, switches or valves intended to be operated by the homeowner.

Operate

To cause to function, turn on, to control the function of a machine, process, or system.

Probing

Examine by touch.

Readily Accessible

Available for visual inspection without requiring moving of personal property, *dismantling*, destructive measures, or any action which will likely involve risk to persons or property.

Readily Openable Access Panel

A panel provided for homeowner inspection and maintenance that is within normal reach, can be removed by one person, and is not sealed in place.

Recreational Facilities

Spas, saunas, steam baths, swimming pools, exercise, entertainment, athletic, playground or other similar equipment and associated accessories.

Report

To communicate in writing.

Representative Number

One *component* per room for multiple similar interior *components* such as windows and electric outlets; one *component* on each side of the building for multiple similar exterior *components*.

Roof Drainage Systems

Components used to carry water off a roof and away from a building.

Sample

A representative portion selected for inspection.

Service Life/Lives

The period during which something continues to function fully as intended.

Significant Deficiency

A clearly definable hazard or a clearly definable potential for failure or is unsafe or not functioning.

Shut Down

A state in which a *system* or *component* cannot be operated by *normal operating controls*.

Solid Fuel Burning Appliances

A hearth and fire chamber or similar prepared place in which a fire may be built and which is built in conjunction with a chimney; or a listed assembly of a fire chamber, its chimney and related factory-made parts designed for unit assembly without requiring field construction.

Structural Component

A component that supports non-variable forces or weights (dead loads) and variable forces or weights (live loads).

System

A combination of interacting or interdependent components, assembled to carry out one or more functions.

Technically Exhaustive

An inspection is technically exhaustive when it is done by a specialist who may make extensive use of measurements, instruments, testing, calculations, and other means to develop scientific or engineering findings, conclusions, and recommendations.

Under-floor Crawl Space

The area within the confines of the foundation and between the ground and the underside of the floor.

Unsafe

A condition in a *readily accessible, installed system* or *component* which is judged to be a significant risk of personal injury during normal, day-to-day use. The risk may be due to damage, deterioration, missing or improper installation or a change in accepted residential construction Standards.

Vapour Barrier

Material used in the building envelope to retard the passage of water vapour or moisture.

Visually Accessible

Able to be viewed by reaching or entering.

Wiring Methods

Identification of electrical conductors or wires by their general type, such as "non-metallic sheathed cable" ("Romex"), "armored cable" ("bx") or "knob and tube", etc.

Note - In these National Standards of Practice, redundancy in the description of the requirements, limitations and exclusions regarding the scope of the Home Inspection is provided for clarity not emphasis.

(CAHPI acknowledges The American Society of Home Inspectors®, Inc. (ASHI®) for the use of their Standards of Practice (version January 1, 2000)

(AUGUST 22/12 VER. F)

ASBESTOS, MOULD AND OTHER ENVIRONMENTAL ISSUES

Environmental issues are outside the scope of a home inspection. Inspectors do not identify or evaluate issues such as asbestos, mould and indoor air quality. Many building materials contain asbestos, although homes built after 1990 are unlikely to have asbestos. Moisture problems may result in visible or concealed mould. There are many sources of indoor air quality issues.

An Environmental Consultant can assist with these types of issues. If you need help, call us at 416-964-9415. More information is available by clicking on the links below.

ASBESTOS

[Health Risks of Asbestos](#) - Government of Canada

VERMICULITE

[Vermiculite Insulation Containing Amphibole Asbestos](#) - Health Canada

MOULD

[MOISTURE AND AIR A Guide for Understanding and Fixing Interior Moisture Problems in Housing](#) - Canada Mortgage and Housing Corporation

AIR QUALITY

[Indoor Air Quality](#) - Health Canada

The links below connect you to a series of documents that will help you understand your home and how it works. These are in addition to links attached to specific items in the report.

Click on any link to read about that system.

» 01. ROOFING, FLASHINGS AND CHIMNEYS

» 02. EXTERIOR

» 03. STRUCTURE

» 04. ELECTRICAL

» 05. HEATING

» 06. COOLING/HEAT PUMPS

» 07. INSULATION

» 08. PLUMBING

» 09. INTERIOR

» 10. APPLIANCES

» 11. LIFE CYCLES AND COSTS

» 12. SUPPLEMENTARY

Asbestos

Radon

Urea Formaldehyde Foam Insulation (UFFI)

Lead

Carbon Monoxide

Mold

Household Pests

Termites and Carpenter Ants

» 13. HOME SET-UP AND MAINTENANCE

» 14. MORE ABOUT HOME INSPECTIONS

